

This specification describes the requirements of **1000W 900W 800W** With full range voltage, switching power supply with an **FLEX-ATX 2.1** form-factor,+5V standby voltage, remote on/off.

## 1. AC input characteristics:

### 1.1 AC input requirements:

The input voltage, current, and frequency requirements for continuous operation are stated show in Table 1.

Table1

Parameter	Min	Nom	Max	Unit
Vin	90	<b>100 --- 240</b>	264	VACrms
Vin Frequency	47	<b>60 --- 50</b>	63	Hz
Iin(1000W)		<b>12.0 --- 6.0</b>		A
Iin(900W)		<b>11.0 --- 5.5</b>		A
Iin(800W)		<b>10.0 --- 5.0</b>		A

### 1.2 AC inrush current(cold start):

The power supply must meet inrush requirements for any rated AC voltage, during turn on at any phase. of AC voltage, during a single cycle AC dropout condition, during repetitive ON/OFF cycling of AC, and over the specified temperature range (Top). The peak inrush current shall be less than the ratings of its critical components (including input fuse, bulk rectifiers, and surge limiting device).

## 2. DC Output characteristics:

### 2.1 Output voltage regulation Requirements:

The power supply output voltage must stay within the following voltage limits shown in Table2 when operating at steady state.

Table2

Parameter	Range	Min	Nom.	Max	Unit
+3.3V	±5%	+3.14	+3.30	+3.47	Volts
+5V	±5%	+4.75	+5.0	+5.25	Volts
+12V	+5%/-7%	+11.20	+12.0	+12.60	Volts
-12V	±10%	-10.8	-12.0	-13.2	Volts
+5VSB	±5%	+4.75	+5.0	+5.25	Volts

## 2.2 Output Current Requirements:

### 2.2.1 Load Range 1000W:

Table3A

Parameter	Min	Max	Peak	Unit
+3.3V	0	<b>15</b>		Amps
+5V	0	<b>15</b>		Amps
+12V	0	<b>83.3</b>		Amps
-12V	0	<b>0.3</b>		Amps
+5VSB	0	<b>2.5</b>	3.0	Amps

Notes:

1. The maximum continuous average DC output power shall not exceed **1000W**.
2. Maximum continuous combined load on +3.3V and +5V outputs shall not exceed 80W.
3. The 12V-2x6 Max load shall not exceed **50A(600W)**.

### 2.2.2 Load Range 900W:

Table3A

Parameter	Min	Max	Peak	Unit
+3.3V	0	<b>15</b>		Amps
+5V	0	<b>15</b>		Amps
+12V	0	<b>75</b>		Amps
-12V	0	<b>0.3</b>		Amps
+5VSB	0	<b>2.5</b>	3.0	Amps

Notes:

1. The maximum continuous average DC output power shall not exceed **900W**.
2. Maximum continuous combined load on +3.3V and +5V outputs shall not exceed 80W.
3. The 12V-2x6 Max load shall not exceed **50A(600W)**.

### 2.2.3 Load Range 800W:

Table3A

Parameter	Min	Max	Peak	Unit
+3.3V	0	<b>15</b>		Amps
+5V	0	<b>15</b>		Amps
+12V	0	<b>66.6</b>		Amps
-12V	0	<b>0.3</b>		Amps
+5VSB	0	<b>2.5</b>	3.0	Amps

ENP8800L Rev:2.0 Enhance Modular		Date: 2026/07/01	Page 2 of 11
-------------------------------------	--	------------------	--------------

**Notes:**

1. The maximum continuous average DC output power shall not exceed **800W**.
2. Maximum continuous combined load on +3.3V and +5V outputs shall not exceed 80W.
3. The 12V-2x6 Max load shall not exceed **37.5A(450W)**.

**2.3 Output Transient Response:**

Table 4 summarizes the expected output transient step sizes for each output.  
 The +3.3V&+5V transient load slew rate is = 1.0 A/μs.  
 The +12V transient load slew rate is = 5.0 A/μs.

Table4

Parameter	Maximum Step Size (% of rated output amps)	Maximum Step Size (A)
+3.3V	30% load	
+5V	30% load	
+12V	85% load	1A
+12V (12V-2x6)	Steps from 100%→300% 30%→100%	
-12V		0.1A
+5VSB		0.5A

**NOTES:**

1. For example, for a rated +5 VDC output of 14A, the transient step would be 30% x 14 A = 4.2 A.
2. Output voltages should remain within the regulation limits of Section 2.1, and the power supply should stable when subjected to load transients per Table 3. from any steady state load, including any or all of the following conditions:
3. Simultaneous load steps on the +12 VDC, +5 VDC, and +3.3 VDC outputs (all steps occurring in the same direction)
4. Load-changing repetition rate of 50 Hz to 10 kHz.
5. AC input range per Section 1.1 and Capacitive loading per Table 8.
6. The +12V min start load is 1A min at dynamic load response test.

**2.4 Output Ripple and Noise:**

Table5

Output	Ripple and Noise	Unit
+3.3V	<b>50</b>	mVp-p
+5V	<b>50</b>	mVp-p
+12V	<b>120</b>	mVp-p
-12V	<b>120</b>	mVp-p
+5VSB	<b>50</b>	mVp-p

ENP8800L Rev:2.0 Enhance Modular		Date: 2026/07/01	Page 3 of 11
-------------------------------------	--	------------------	--------------

**Note:**

This is measured over a bandwidth of 10Hz to 20MHz at the power supply output connector. A 10µF electrolytic capacitor in a parallel with a 0.1µF ceramic capacitor is placed at the point of measurement.

**Differential noise test setup**

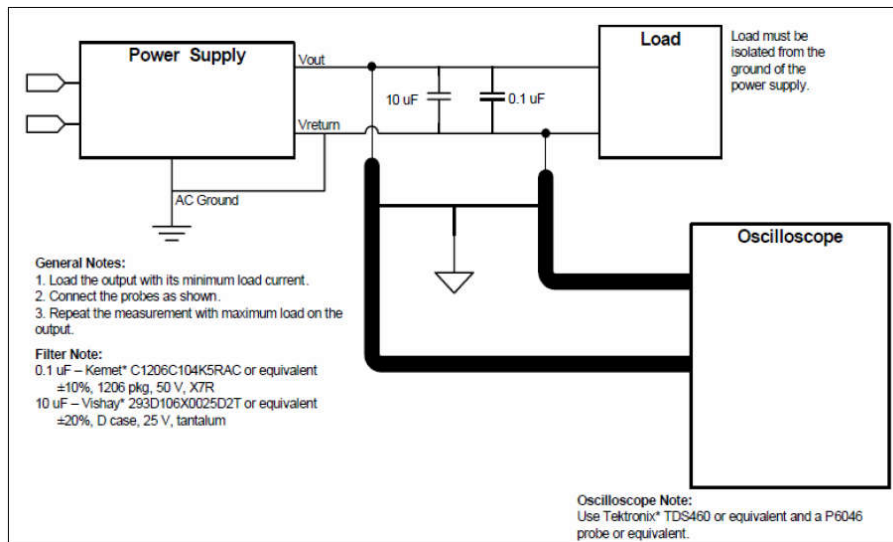

**2.5 Efficiency:**

2.5.1 In the 115Vac/60Hz input voltage the power supply efficiency is more than 89%.

**Table6A / 1000W, 900W :**

Load	Efficiency(%)	Power Factor
10W/2%	<b>60</b>	
20%	<b>90</b>	
50%	<b>92</b>	>0.95
100%	<b>89</b>	>0.95

**Notes:**

1. The 10W DC load values are the same for all PSU that are less than 500W.
2. There is 0.5% tolerance in mass production.

2.5.2 In the 115Vac/60Hz input voltage the power supply efficiency is more than 89%.

**Table6A / 800W :**

Load	Efficiency(%)	Power Factor
10W/2%	<b>60</b>	
20%	<b>87</b>	
50%	<b>90</b>	>0.95
100%	<b>87</b>	>0.95

ENP8800L Rev:2.0 Enhance Modular		Date: 2026/07/01	Page 4 of 11
-------------------------------------	--	------------------	--------------

**Notes:**

1. The 10W DC load values are the same for all PSU that are less than 500W.
2. There is 0.5% tolerance in mass production.

**2.5.3 ERP 5VSB Efficiency**

Table7

+5VSB LOAD	Efficiency target (both 115V and 230V input)
2.5A	75%
1.5A	75%
1A	75%
0.55A	75%
90mA	55%
45mA	45%

**2.6 Remote on/off control**

When the logic level "PS-ON" is low, the DC outputs are to be enabled.  
 When the logic level is high or open collector, the DC outputs are to be disabled.

**2.7 Overshoot:**

The overshoot of the DC output voltage caused by switching AC power or switch PSON# should be less than 10% of the normal output, and no reverse polarity voltage should be produced.

**2.8 Capacitance Loading**

The power supply shall be stable and meet all requirements with the following capacitive Loading ranges.

Table8

Capacitive Loading Conditions	
Output	Capacitive Load (μF)
+3.3V	3,300
+5V	3,300
+12V	3,300
-12V	3,30
+5VSB	3,300

**3.Environment:**

**3.1 Operation temperature:**

Table9

Temperature	<b>0 to 50°C</b>
Relative Humidity	5% to 90%,non-condensing

**3.2 Shipping and Storage:**

Table10

Temperature	<b>-40°C ~70°C</b>
Relative Humidity	5% to 95%,non-condensing

ENP8800L Rev:2.0 Enhance Modular		Date: 2026/07/01	Page 5 of 11
-------------------------------------	--	------------------	--------------

**3.3 Altitude:** Table11

Operating	≤5000m
Storage	≤5000m

**3.4 Cooling mode:**  
Forced air cooling.

**3.5 Random Vibration:**  
Non-operating 0.01 g<sup>2</sup>/Hz at 5 Hz, sloping to 0.02 g<sup>2</sup>/Hz at 20 Hz, and maintaining 0.02 g<sup>2</sup>/Hz from 20 Hz to 500 Hz. The area under the PSD curve is 3.13 grams.  
The duration shall be 10 minutes per axis for all three axes on all samples.

**4. Protection:**  
Due to overvoltage, over power and short circuit, the protection function of the power supply circuit is self operated, and the power is self locked. There is no output at that time. When these reasons are removed, the power is restored to the normal output state when the power is restarted. (PSON# at least 1 second; AC shutdown at least 4 seconds).

**4.1 Over-power protection**  
The power supply will be shutdown and latch off when output power within 110~160% of rated DC output.  
Note: Assurance machine can work at low voltage, full load won't damage machine.

**4.2 Over voltage protection:** Table12

Output	Output voltage protection point			Unit
	Min	Nom	Max	
+3.3V	3.76	4.2	4.3	V
+5V	5.74	6.3	7.0	V
+12V	13.4	15.0	15.6	V
+5VSB	5.74	6.3	7.0	V

**4.3 Short circuit protection:**  
An output short circuit is defined as any output impedance of less than 0.1ohms.The power supply shall shut down and latch off for shorting the +3.3 VDC,+5 VDC,or+12VDC rails to return or any other rail. Shorts between main output rails and +5VSB shall not cause any damage to the power supply. The power supply shall either shut down and latch off or fold back for shorting the negative rails +5VSB must be capable of being shorted indefinitely, but when the short is removed the power supply shall recover automatically or by cycling PS\_ON#. The power supply shall be capable of withstanding a continuous short-circuit to the output without damage or overstress to the unit

**4.4 Over Temperature Protection:**  
The power supply will be protected against over temperature conditions caused by loss of fan cooling or excessive ambient temperature. In an OTP condition the PSU will shutdown. When the power supply temperature drops to within specified limits, the power supply shall Latch mode.

ENP8800L Rev:2.0 Enhance Modular	Date: 2026/07/01	Page 6 of 11
-------------------------------------	------------------	--------------

## 4.5 Over current protection

The power supply shall have current limit to prevent the +3.3 V, +5 V, and +12V outputs from exceeding the values shown in Table . If the current limits are exceeded the power supply shall shutdown and latch off. The damaged from repeated power cycling in this condition. -12V and 5VSB shall be protected under over current or shorted conditions so that no damage can occur to the power supply. All outputs shall be protected so that no damage occurs to the power supply under a shorted output condition.

Table13

Voltage	Over Current Limit (I <sub>out</sub> limit)
+3.3V	17A minimum; 25A maximum
+5V	17A minimum; 25A maximum
+12V(1000W)	100A minimum; 133A maximum
+12V(900W)	90A minimum; 120A maximum
+12V(800W)	80A minimum; 107A maximum

## 5. Power Supply Timing

### 5.1 Signal timing drawing

Figure 2 is a reference for signal timing for main power connector signals and rails.

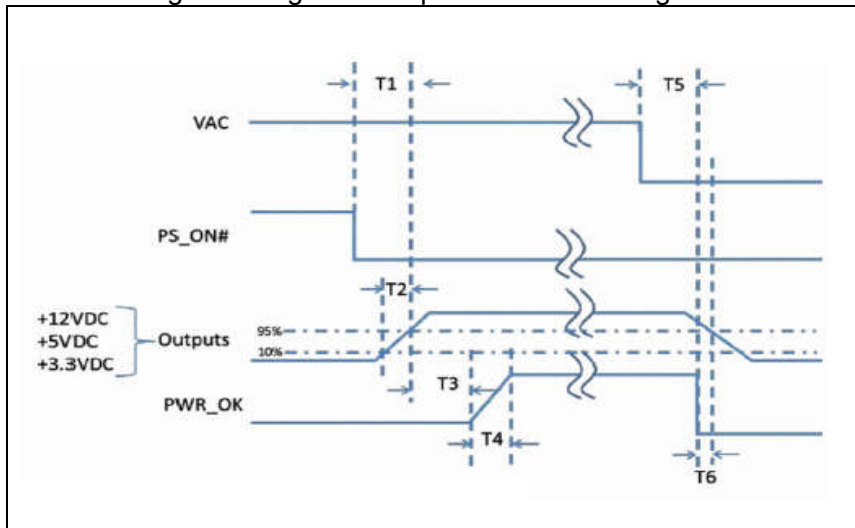

Table14

Parameter	Description	Required
T0	AC power on time	<2s
T1	Power-on time	< 150ms
T2	Rise time	0.2 – 20 ms
T3	PWR_OK delay	100 – 150ms
T4	PWR_OK rise time	< 10 ms
T5	AC loss to PWR_OK hold-up time (at 75% load)	> 11 ms
T6	PWR_OK inactive to DC loss delay (at 75% load)	> 1 ms

The power supply should maintain output regulations per Table 5 despite a loss of input power at the low-end nominal range-115 VAC / 47 Hz or 230 VAC / 47 Hz – at maximum continuous output load as applicable for a minimum of 12ms (T5+T6)

## 6. SAFETY:

The power supply designed to meet **IEC 62368-1**.

### 6.1 EMC

- 6.4.1 ELECTROSTATIC DISCHARGE (ESD) – IEC 61000-4-2(EN 61000-4-2).
- 6.4.2 RADIATED SUSCEPTIBILITY – IEC 61000-4-3(EN 61000-4-3).
- 6.4.3 ELECTRICAL FAST TRANSIENT / BURST (EFT/B) – IEC 61000-4-4 (EN 61000-4-4).
- 6.4.4 SURGE – IEC 61000-4-5(EN 61000-4-5).
- 6.4.5 CONDUCTED SUSCEPTIBILITY – IEC 61000-4-6(EN 61000-4-6).
- 6.4.6 POWER FREQUENCY MAGNETIC FIELD – IEC 61000-4-8(EN 61000-4-8).
- 6.4.7 VOLTAGE DIPS – IEC 61000-4-11(EN 61000-4-11).
- 6.4.8 VOLTAGE FLUCTUATIONS – IEC 61000-3-3 (EN 61000-3-3).
- 6.4.9 HARMONIC CURRENT EMISSION – IEC61000-3-2(EN 61000-3-2).
- 6.4.10 EN55032:Class B Radio interference (CISPR 32).
- 6.4.11 ANSI C63.4-2014 / FCC Part 15 Subpart B / ICES-003 Issue 6 Class B 115VAC operation.

## 7. Reliability:

The demonstrated MTBF shall be **100,000 hours** of continuous operation at 25°C and full load and nominal voltage. The MTBF of the power supply shall be calculated in accordance with MIL-HDBK-217F. The DC FAN is not included.

**8. Mechanical:**

**8.1 Physical dimension: L165mm\*W81.5mm\*H40.5mm**

( 線材組合&外露長度僅供參考，可根據客戶要求更改或新增。 )

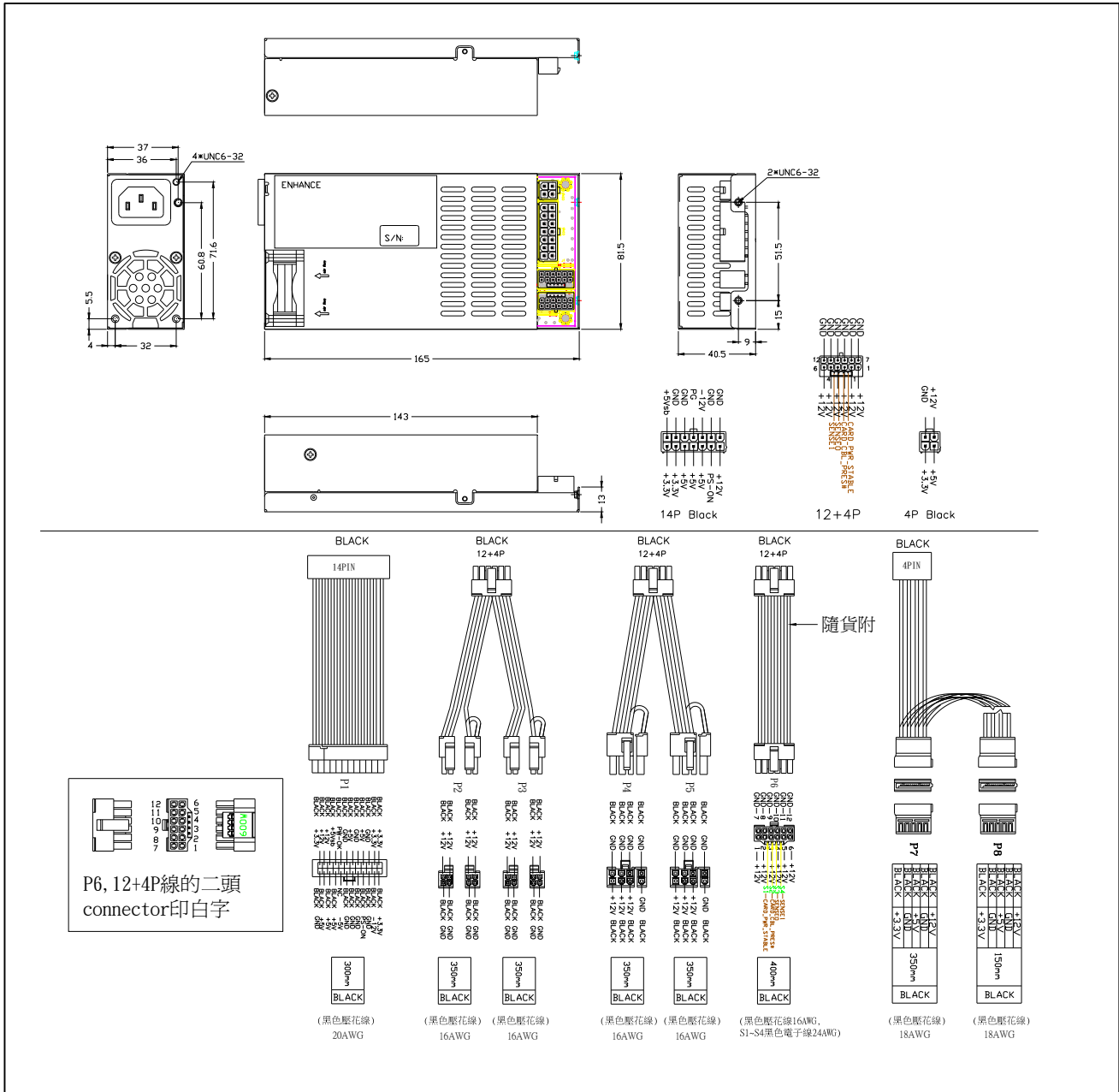

ENP8800L Rev:2.0 Enhance Modular		Date: 2026/07/01	Page 9 of 11
-------------------------------------	--	------------------	--------------

## 8.2 Connectors (INTEL approved equivalent):

### M/B 20+4PIN Connector (Molex C4202H02-2\*12PB or equivalent)

18AWG wire	Signal	Pin	Pin	Signal	18AWG wire
Black	+3.3V	11	1	+3.3V	Black
Black	-12VDC(22AWG)	12	2	+3.3V	Black
Black	GND	13	3	GND	Black
Black	PS-ON(22AWG)	14	4	+5VDC	Black
Black	GND	15	5	GND	Black
Black	GND	16	6	+5VDC	Black
Black	GND	17	7	GND	Black
Black	NC	28	8	POK(22AWG)	Black
Black	+5VDC	19	9	+5VSB	Black
Black	+5VDC	20	10	+12VDC	Black
Black	+5VDC	B3	B1	+12VDC	Black
Black	GND	B4	B2	+3.3V	Black

### CPU (4+4)PIN Connector (Molex P4-I42002BK3B) or equivalent)

16AWG wire	Signal	Pin	Pin	Signal	16AWG wire
Black	+12V	3	1	GND	Black
Black	+12V	4	2	GND	Black

### PCIe(6+2)PIN : Molex AP102XN8T1-204X-RS1 or equivalent

16AWG wire	Signal	Pin	Pin	Signal	16AWG wire
Black	+12V	1	4	GND	Black
Black	+12V	2	5	GND	Black
Black	+12V	3	6	GND	Black
Black	GND	1	2	GND	Black

### HDD 4PIN Connector (Molex C5082H02-4PB or equivalent)

18AWG wire	Signal	Pin
Black	+12V	1
Black	GND	2
Black	GND	3
Black	+5V	4

### SATA 5PIN Connector (Molex P5-112702T00 or equivalent)

18AWG wire	Signal	Pin
Black	+3.3V	5
Black	GND	4
Black	+5V	3
Black	GND	2
Black	+12V	1

### PCIe 12+4PIN : 12V-2x6 Auxiliary Power Connector Pin Assignment

16AWG wire	Signal	Pin	Pin	Signal	16AWG wire
Black	+12V	1	7	GND	Black
Black	+12V	2	8	GND	Black
Black	+12V	3	9	GND	Black
Black	+12V	4	10	GND	Black
Black	+12V	5	11	GND	Black
Black	+12V	6	12	GND	Black
Black(24AWG)	CARD_PWR_STABLE	S1	S3	SENSE0	Black(24AWG)
Black(24AWG)	CARD_CBL_PRES#	S2	S4	SENSE1	Black(24AWG)

## 9. FAN SPEED CONTROL

1. Fan voltage varies with the ambient temperature or output power.

ENP8800L Rev:2.0 Enhance Modular		Date: 2026/07/01	Page 11 of 11
-------------------------------------	--	------------------	---------------

AUDIT: CHY CHECK: HXX DESIGN: Gary