

MODEL NO. ENP-7100-S SERIES(SA,SD,SH,SJ,SF) (ACTIVE PFC)

This specification describes the requirements of **300W,350W,400W,450W** with full range voltage, switching power supply with a Micro-ATX(SFX-1.0&1.1) form-factor and SFX 12V, +5V standby voltage, remote on/off. (SD,SH series have safety,SA,SJ,SF series no safety)

1.0 AC INPUT

1.1 AC input requirements

The input voltage, current, and frequency requirements for continuous operation are stated below

Table 1 AC Input Line Requirements

Parameter	Min	Nom	Max	Unit
Vin	90	100-240	264	VACrms
Vin Frequency	47	60---50	63	Hz
lin(300W)		4.0--2.0		Arms
lin(350W)		5.0--2.5		Arms
lin(400W)		6.0--3.0		Arms
lin(450W)		7.0--3.5		Arms

Power factor correction (PF)>0.90 at full load.

1.2 Inrush current regulation

The power supply must meet inrush requirements for any rated AC voltage, during turn on at any phase of AC voltage, during a single cycle AC dropout condition, during repetitive ON/OFF cycling of AC,and over the specified temperature range (Top). The peak inrush current shall be less than the ratings of its critical components (including input fuse, bulk rectifiers, and surge limiting device).

2.0 DC OUTPUT

2.1 DC voltage regulation

Parameter	Range	Min	Nom.	Max	Unit
+3.3V	±5%	+3.14	+3.3	+3.47	Volts
+5V	±5%	+4.75	+5.0	+5.25	Volts
+12V	±5%	+11.4	+12.0	+12.6	Volts
-12V	±10%	-10.8	-12.0	-13.2	Volts
+5VSb	±5%	+4.75	+5.0	+5.25	Volts

(1)At no load,3.3V output +/-5% regulation limits do not apply.

2.2 LOAD RANGE

2.2.1 Load Range

300W(單組)

Parameter	Min	Nom.	Max	Peak	Unit
+3.3V	0	-	15		Amps
+5V	0	-	14		Amps
+12V	0	-	25		Amps
-12V	0	-	0.3		Amps
+5VSb	0	-	2.5		Amps

(1) The maximum combined load on +3.3V and +5V outputs shall not exceed 90W.

(2) Maximum continuous total DC output power should not exceed 300W.

300W(雙組)

Parameter	Min	Nom.	Max	Peak	Unit
+3.3V	0	-	15		Amps
+5V	0	-	14		Amps
+12V1	0	-	16	18	Amps
+12V2	0	-	16	18	Amps
-12V	0	-	0.3		Amps
+5VSb	0	-	2.5		Amps

(1) The maximum combined load on +3.3V and +5V outputs shall not exceed 90W.

(2) The maximum combined load on +12V1 and +12V2 outputs shall not exceed 300W.

(3) Maximum continuous total DC output power should not exceed 300W.

2.2.2 Load Range

350W(單組)

Parameter	Min	Nom.	Max	Peak	Unit
+3.3V	0	-	15		Amps
+5V	0	-	14		Amps
+12V	0	-	29		Amps
-12V	0	-	0.3		Amps
+5VSb	0	-	2.5		Amps

(1) The maximum combined load on +3.3V and +5V outputs shall not exceed 90W.

(2) Maximum continuous total DC output power should not exceed 350W.

350W(雙組)

Parameter	Min	Nom.	Max	Peak	Unit
+3.3V	0	-	15		Amps
+5V	0	-	14		Amps
+12V1	0	-	16	18	Amps
+12V2	0	-	16	18	Amps
-12V	0	-	0.3		Amps
+5VSb	0	-	2.5		Amps

- (1) The maximum combined load on +3.3V and +5V outputs shall not exceed 90W.
- (2) The maximum combined load on +12V1 and +12V2 outputs shall not exceed 350W.
- (3) Maximum continuous total DC output power should not exceed 350W.

2.2.3 Load Range

400W(單組)

Parameter	Min	Nom.	Max	Peak	Unit
+3.3V	0	-	17		Amps
+5V	0	-	14		Amps
+12V	0	-	33		Amps
-12V	0	-	0.3		Amps
+5VSb	0	-	2.5		Amps

- (1) The maximum combined load on +3.3V and +5V outputs shall not exceed 90W.
- (2) Maximum continuous total DC output power should not exceed 400W.

400W(雙組)

Parameter	Min	Nom.	Max	Peak	Unit
+3.3V	0	-	17		Amps
+5V	0	-	14		Amps
+12V1	0	-	18		Amps
+12V2	0	-	18		Amps
-12V	0	-	0.3		Amps
+5VSb	0	-	2.5		Amps

- (1) The maximum combined load on +3.3V and +5V outputs shall not exceed 90W.
- (2) The maximum combined load on +12V1 and +12V2 outputs shall not exceed 400W.
- (3) Maximum continuous total DC output power should not exceed 400W.

2.2.4 Load Range

450W(單組)

Parameter	Min	Nom.	Max	Peak	Unit
+3.3V	0	-	19		Amps
+5V	0	-	14		Amps
+12V	0	-	37		Amps
-12V	0	-	0.3		Amps
+5VSb	0	-	2.5		Amps

- (1) The maximum combined load on +3.3V and +5V outputs shall not exceed 90W.
- (2) Maximum continuous total DC output power should not exceed 450W.

450W(雙組)

Parameter	Min	Nom.	Max	Peak	Unit
+3.3V	0	-	19		Amps
+5V	0	-	14		Amps
+12V1	0	-	20		Amps
+12V2	0	-	20		Amps
-12V	0	-	0.3		Amps
+5VSb	0	-	2.5		Amps

- (1) The maximum combined load on +3.3V and +5V outputs shall not exceed 90W.
- (2) The maximum combined load on +12V1 and +12V2 outputs shall not exceed 450W.
- (3) Maximum continuous total DC output power should not exceed 450W.

2.3 Output Ripple

2.3.1 Ripple regulation

Parameter	Ripple&Noise	Unit
+3.3V	50	mVp-p
+5V	50	mVp-p
+12V	120	mVp-p
-12V	120	mVp-p
+5VSb	50	mVp-p

2.3.2 Definition

The ripple voltage of the outputs shall be measured at the pins of the output connector when terminated in the load impedance specified in figure1. Ripple and noise are measured at the connectors with a 0.1uF ceramic capacitor and a 10uF electrolytic capacitor to simulate system loading. Ripple shall be measured under any condition of line voltage, output load, line frequency, operation temperature.

2.3.3 Ripple voltage test circuit

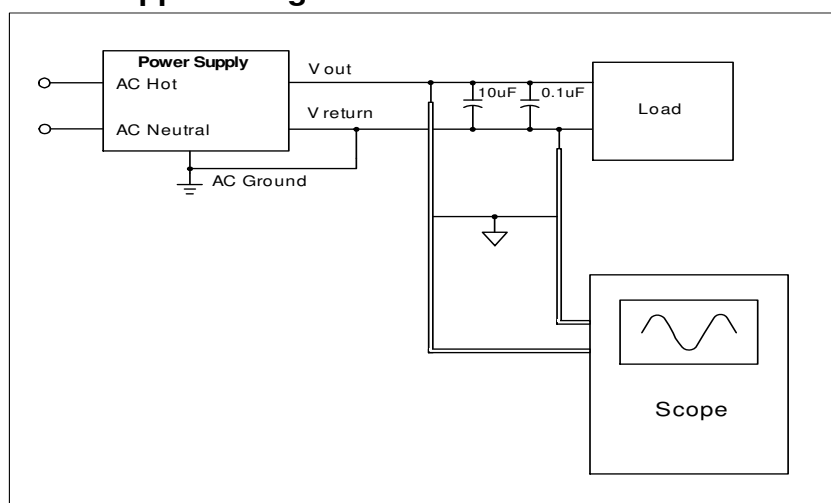

Figure 1. Ripple voltage test circuit

2.4 Overshoot

Any overshoot at turn on or turn off shall be less 10% of the nominal voltage value, all outputs shall be within the regulation limit of section 2.0 before issuing the power good signal of section 5.0.

2.5 Efficiency

Power supply efficiency typical 87% for 350W,400W,450W, 85% for 300W at normal AC main voltage and full load on all outputs.

2.6 Remote on/off control

When the logic level "PS-ON" is low, the DC outputs are to be enabled.

When the logic level is high or open collector, the DC outputs are to be disabled.

☞ 3.0 PROTECTION

3.1 Over-power protection

The power supply will be shutdown and latch off when output power over 110% ~ 160% of rated DC output.

3.2 Over current protection

The power supply shall have current limit to prevent the +3.3V,+5V,and +12V1,+12V2 outputs from exceeding the values shown in the following Table. If the current limits are exceeded the power supply shall shutdown and latch off.

300W(單組)

Voltage	Over Current Limit (Iout limit)
+12V	27A minimum; 37A maximum
+5V	20A minimum; 50A maximum
+3.3V	20A minimum; 50A maximum

300W(雙組)

Voltage	Over Current Limit (Iout limit)
+12V1	20A minimum; 40A maximum
+12V2	20A minimum; 40A maximum
+5V	20A minimum; 50A maximum
+3.3V	20A minimum; 50A maximum

350W(單組)

Voltage	Over Current Limit (Iout limit)
+12V	31A minimum; 41A maximum
+5V	20A minimum; 50A maximum
+3.3V	20A minimum; 50A maximum

350W(雙組)

Voltage	Over Current Limit (lout limit)
+12V1	20A minimum; 40A maximum
+12V2	20A minimum; 40A maximum
+5V	20A minimum; 50A maximum
+3.3V	20A minimum; 50A maximum

400W(單組)

Voltage	Over Current Limit (lout limit)
+12V	35A minimum; 45A maximum
+5V	20A minimum; 50A maximum
+3.3V	20A minimum; 50A maximum

400W(雙組)

Voltage	Over Current Limit (lout limit)
+12V1	20A minimum; 40A maximum
+12V2	20A minimum; 40A maximum
+5V	20A minimum; 50A maximum
+3.3V	20A minimum; 50A maximum

450W(單組)

Voltage	Over Current Limit (lout limit)
+12V	39A minimum; 49A maximum
+5V	20A minimum; 50A maximum
+3.3V	20A minimum; 50A maximum

450W(雙組)

Voltage	Over Current Limit (lout limit)
+12V1	22A minimum; 40A maximum
+12V2	22A minimum; 40A maximum
+5V	20A minimum; 50A maximum
+3.3V	20A minimum; 50A maximum

3.3 Over voltage protection

The over voltage sense circuitry and reference shall reside in packages that are separate and distinct from the regulator control circuitry and reference. No single point fault shall be able to cause a sustained over voltage condition on any or all outputs. The supply shall provide latch-mode over voltage protection as defined in Table.

Output	Minimum	Nominal	Maximum	Unit
+12 VDC	13.4	15.0	16.5	Volts
+5 VDC	5.74	6.3	7.0	Volts
+3.3 VDC	3.76	4.2	5.1	Volts

3.4 Short circuit

An output short circuit is defined as any output impedance of less than 0.1 ohms. The power supply shall shut down and latch off for shorting the +3.3 VDC,+5 VDC,or+12 VDC rails to return or any other rail. Shorts between main output rails and +5VSB shall not cause any damage to the power supply. The power supply shall either shut down and latch off or fold back for shorting the negative rails.+5VSB must be capable of being shorted indefinitely, but when the short is removed,the power supply shall recover automatically or by cycling PS_ON#.The power supply shall be capable of withstanding a continuous short-circuit to the output without damage or overstress to the unit

3.5 No load operation

No damage or hazardous condition should occur with all the DC output connectors disconnecte from the load. The power supply may latch into the shutdown state.

3.6 Under voltage protection.

In an under voltage fault occurs, the supply will latch all DC outputs into a shutdown state when +12V,+5V & +3.3V outputs under 85% of it's maximum value.

4.0 TIMING

4.1 Signal timing drawing

Figure 2 is a reference for signal timing for main power connector signals and rails.

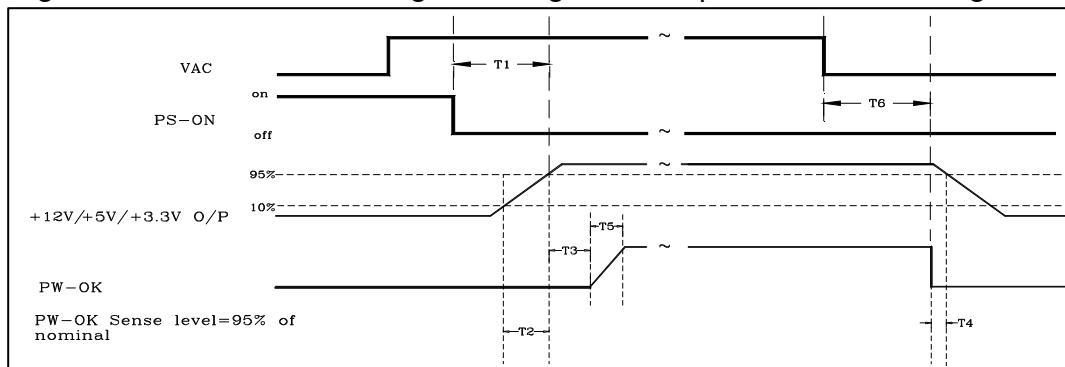

Figure 2. PS-OK Timing Sequence

- (1)T2: Rise time (0.2ms~20ms)
- (2)T3: Power good signal turn on delay time (100ms~500ms)
- (3)T4: Power good signal turn off delay time (1ms min)
- (4)T5: Rise time (10ms max)

4.2 .Output Transient Response

Table 13. summarizes the expected output transient step sizes for each output. The transient load slew rate is =1.0A/us.

Table 13. DC Output Transient Step Sizes

Output	Max.step size	
	(% of rated output amps per Sec 3.2.3) ⁽¹⁾	(amps)
+12VDC	40%	
+5VDC	30%	
+3.3VDC	30%	
-12VDC		0.1A
+5VSB		0.5A

⁽¹⁾ For example, for a rated +5 VDC output of 18A,the transient step would be 30% x 18A=5.4/ Output voltages should remain within the regulation limits of Section 2.1,and the power supply should stable when subjected to load transients per Table 13. from any steady state load, including any or all of the following conditions:
 Simultaneous load steps on the +12 VDC,+5 VDC,and +3.3 VDC outputs (all steps occurring in the same direction)
 Load-changing repetition rate of 50 Hz to 10 kHz
 AC input range per Section 1.0

4.3 Hold up time

When the power loss its input power, it shall maintain 16ms at full load in regulation for 300W limit at normal input voltage. (AC:115V/60Hz or 230V/50Hz)
 When the power loss its input power, it shall maintain 16ms at 75% load in regulation for 350W,400W,450W limit at normal input voltage. (AC:115V/60Hz or 230V/50Hz)

5.0 ENVIRONMENT

5.1 Operation

Temperature	0 to 50 °C (300W-400W)
Relative Humidity	to 85%,on-condensing

Temperature	0 to 40 °C (450W)
Relative Humidity	to 85%,on-condensing

5.2 Shipping and Storage

Temperature	-20 to 90°C
Relative Humidity	to 95%,non-condensing

5.3 Altitude

Operating	10,000FT max.
Storage	50,000FT max.

6.0 SAFETY

6.1 Underwriters Laboratory (UL) recognition.

The power supply designed to meet UL 60950

F型 , Dim (L125*W100*H63.5)

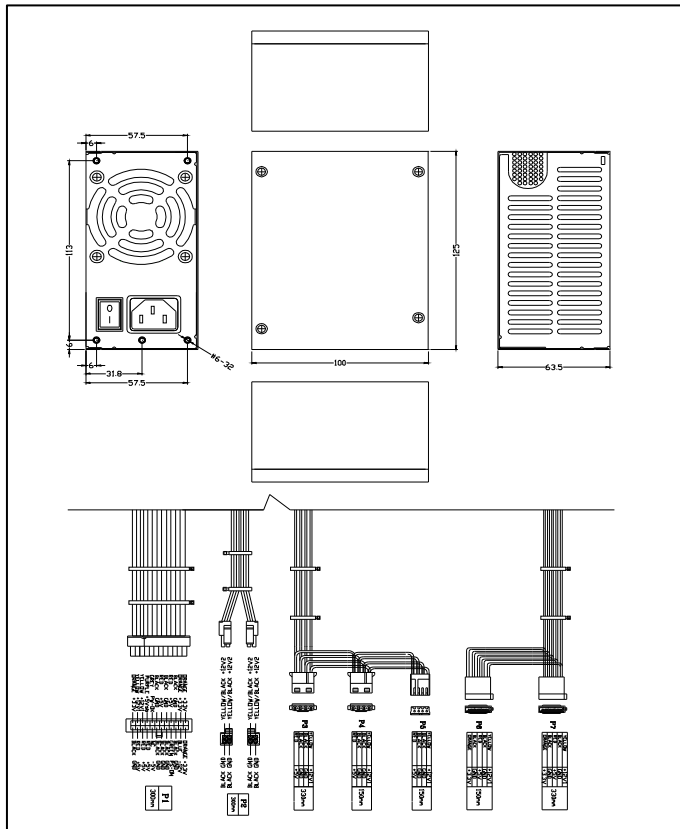

H型 , Dim (L125*W100*H63.5)

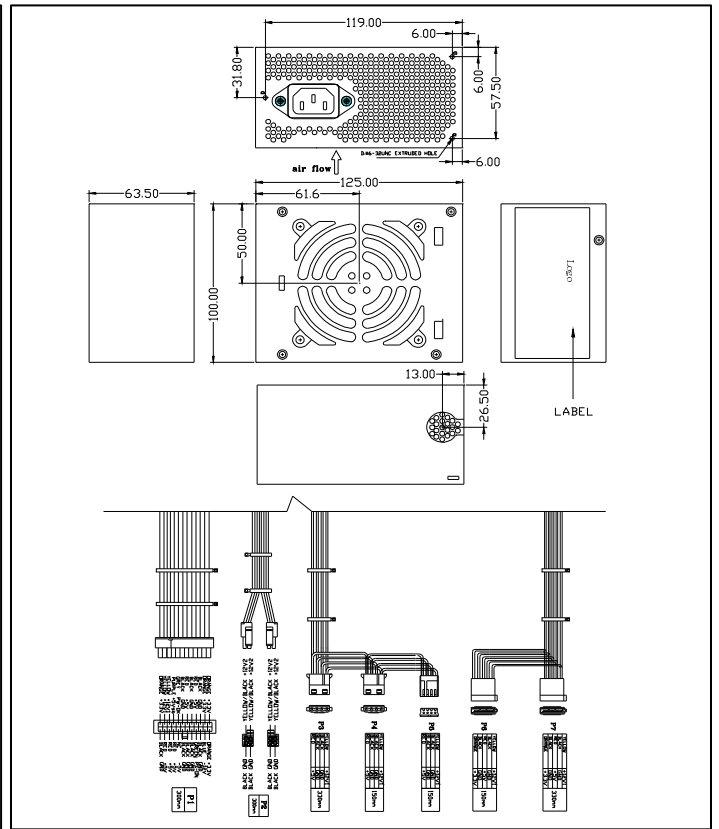

J型 , Dim (L125*W100*H63.5)

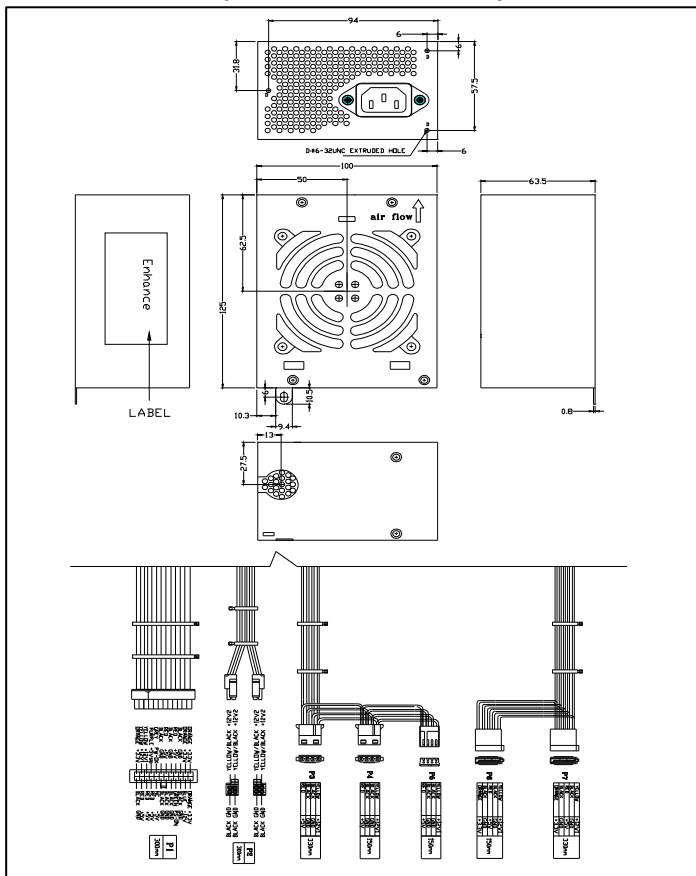

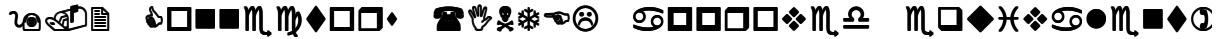

P1 connector (Molex 39-01-2200 or equivalent)

20AWG wire	Signal	Pin	Pin	Signal	20AWG wire
Orange	+3.3V	11	1	+3.3V	Orange
Orange(22AWG)	3.3 sense				
Blue	-12VDC	12	2	+3.3V	Orange
Black	COM	13	3	COM	Black
Green	PS-ON	14	4	+5VDC	Red
Black	COM	15	5	COM	Black
Black	COM	16	6	+5VDC	Red
Black	COM	17	7	COM	Black
White	NC	18	8	POK	Grey
Red	+5VDC	19	9	+5VSB	Purple
Red	+5VDC	20	10	+12VDC	Yellow

P3,P4(AMP 1-480424-0 or Molex 8981-04P or equivalent)

P5 (AMP 171822-4 or equivalent)

20 AWG wire	Signal	Pin	Pin	Signal	22AWG wire
Yellow	+12VDC	1	1	+5VDC	Red
Black	COM	2	2	COM	Black
Black	COM	3	3	COM	Black
Red(optional)	+5VDC	4	4	+12VDC	Yellow

P2 Optional Connector (Molex 39-01-2060 or equivalent)

20 AWG wire	Signal	Pin	Pin	Signal	20AWG wire
Black	GND	1	3	+12V2	Yellow
Black	GND	2	4	+12V2	Yellow

P6,P7 (optional) Serial ATA Power Connector (Molex* 88751 or equivalent)

18 / 20AWG wire	Signal	Pin
Orange	+3.3V	5
Black	GND	4
Red	+5V	3
Black	GND	2
Yellow	+12V	1

10. FAN SPEED CONTROL

Fan voltage varies with the ambient temperature and/or output power.