

MODEL NO. ATX1915

This specification describes the requirements of **1500Watts** switching power supply with an stretch ATX form-factor and EPS 12V, +5V standby voltage, remote on/off control, full range line input capability and forced air cooling characteristics.

1. AC INPUT

1.1 AC input requirements

The input voltage, current, and frequency requirements for continuous operation are stated below.

Table 1 AC Input Line Requirements

Parameter	Min.	Nom.	Max.	Unit
Vin(Full range)	90	100 --- 240	264	VACrms
Vin Frequency	47	60 ----- 50	63	Hz
lin		16 ----- 8.0		Arms

Power factor correction (PF)>0.90 at full load.

The power supply must meet inrush requirements for any rated AC voltage, during turn on at any phase of AC voltage, during a single cycle AC dropout condition, during repetitive ON/OFF cycling of AC, and over the specified temperature range (Top). The peak inrush current shall be less than the ratings of its critical components (including input fuse, bulk rectifiers, and surge limiting device).

2. DC OUTPUT

2.1 DC voltage regulation

Parameter	Range	Min	Nom.	Max	Unit
+3.3V	+/-5%	+3.14	+3.30	+3.47	Volts
+5V	+/-5%	+4.75	+5.00	+5.25	Volts
+12V	+/-5%	+11.40	+12.00	+12.60	Volts
-12V	+/-10%	-13.2	-12.00	-10.8	Volts
+5VSB	+/-5%	+4.75	+5.00	+5.25	Volts

Note:1>Voltage tolerance is required at main connector and S-ATA connector(if used)

2.2 Load ranges

Parameter	Min(optional)	Nom.	Max	Peak	Unit
+3.3V	0	-	25		Amps
+5V	0	-	22		Amps
+12V	0.15	-	125		Amps
-12V	0	-	0.3		Amps
+5VSB	0	-	3		Amps

1. Maximum continuous combined load on +3.3V and +5V outputs shall not exceed 120W.

2. Maximum continuous total DC output power should not exceed 1500W.

3. Peak DC output power should not exceed **1600W for 12 second.**

2.3 Output Ripple

2.3.1 Ripple regulation

Parameter	Ripple&Noise	Unit
+3.3V	50	mVp-p
+5V	50	mVp-p
+12V	120	mVp-p
-12V	120	mVp-p
+5VSB	50	mVp-p

2.3.2 Definition

The ripple voltage of the outputs shall be measured at the pins of the output connector when terminated in the load impedance specified in figure 1. Ripple and noise are measured at the connectors with a 0.1uF ceramic capacitor and a 10uF electrolytic capacitor to simulate system loading. Ripple shall be measured under any condition of line voltage, output load, line frequency, operation temperature.

2.3.3 Ripple voltage test circuit

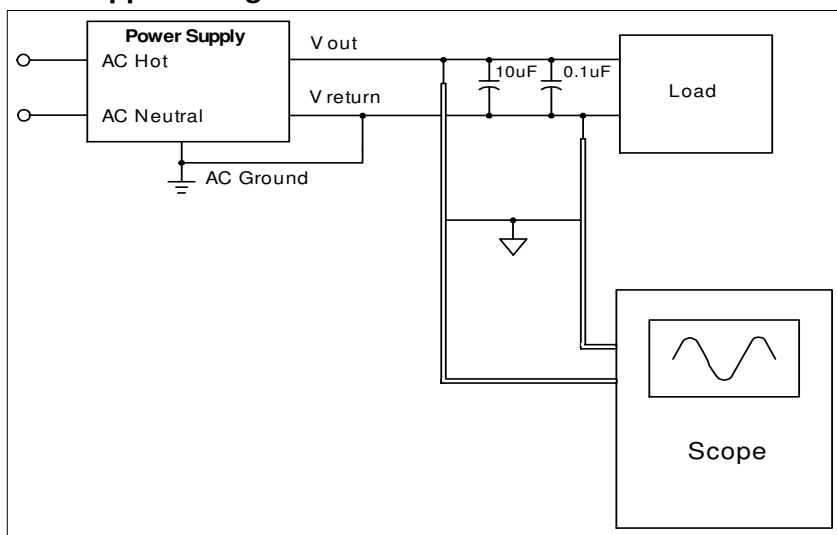

Figure 1. Ripple voltage test circuit

2.4 Overshoot

Any overshoot at turn on or turn off shall be less 10% of the nominal voltage value, all outputs shall be within the regulation limit of section 2.0 before issuing the power good signal of section 5.0.

2.5 Efficiency

At 115Vac

load	Efficiency	PF
10%	90%	0.95
20%	92%	0.95
50%	94%	0.95
100%	90%	0.95

2.6 Remote ON/OFF control

When the logic level "PS-ON" is low, the DC outputs are to be enabled.

When the logic level is high or open collector, the DC outputs are to be disabled.

3.0 PROTECTION

3.1 Over current protection

The power supply shall have current limit to prevent the +3.3V,+5V,and +12V outputs from exceeding the values shown in the following Table.If the current limits are exceeded the power supply shall shutdown and latch off.

Voltage	Over Current Limit (Iout limit)
+12V	130A minimum; 160A maximum
+5V	28A minimum; 48A maximum
+3.3V	28A minimum; 48A maximum

3.2 Over Temperature Protection

The power supply will be protected against over temperature conditions caused by loss of fan cooling or excessive ambient temperature.In an OTP condition the PSU will shutdown.When the power supply temperature drops to within specifide limits,the power supply shall restore power automatically.The OTP circuit must have built in hysteresis such that the power supply will not oscillate on and off due to temperature recovering condition.

3.3 Over-power protection

The power supply will be shutdown and latch off when output power within 110~150% of rated DC output.

Note: Assurance machine can work at low voltage,full load won't damage machine.

3.4 Under voltage protection.

In an under voltage fault occurs, the supply will latch all DC outputs into a shutdown state when +12V,+5V & +3.3V outputs under 85% of it's maximum value.

3.5 Over voltage protection

The over voltage sense circuitry and reference shall reside in packages that are separate and distinct from the regulator control circuitry and reference.No single point fault shall be able to cause a sustained over voltage condition on any or all outputs.The supply shall provide latch-mode over voltage protection as defined in Table.

Output	Minimum	Nominal	Maximum	Unit
+12V VDC	13	15	17	Volts
+5 VDC	5.5	6	7	Volts
+3.3 VDC	3.6	4	5	Volts

3.6 Short circuit

An output short circuit is defined as any output impedance of less than 0.1 ohms.The power supply shall shut down and latch off for shorting the +3.3 VDC,+5 VDC,or+12VDC rails to return or any other rail. Shorts between main output rails and +5VSB shall not cause any damage to the power supply. The power supply shall either shut down and latch off or fold back for shorting the negative rails.+5VSB must be capable of being shorted indefinitely,but when the short is removed, the power supply shall recover automatically or by cycling PS_ON#.The power supply shall be capable of withstanding a continuous short-circuit to the output without damage or overstress to the unit

3.7 No load operation

AUDIT: _____ CHECK: _____ DESIGN: _____

No damage or hazardous condition should occur with all the DC output connectors disconnected from the load. The power supply may latch into the shutdown state.

4. TIMING

4.1 Signal timing drawing

Figure 2. is a reference for signal timing for main power connector signals and rails.

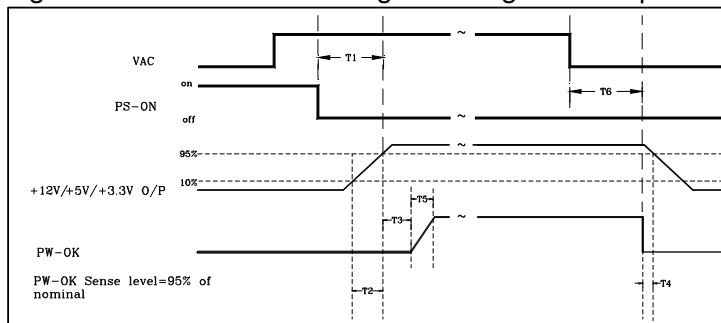

Figure 2. PS-OK Timing Sequence

- (1) T3: Power good signal turn on delay time (100ms~500ms)
- (2) T4: Power good signal turn off delay time (75%Load 1ms min)
- (3) T2: Rise time (0.1~20ms)
- (4) T6: Hold up time (75%Load 16ms Min)

4.2 Hold up time

When the power loss its input power, it shall maintain **16ms** in regulation limit at normal input voltage and **75%** load (AC:115V/60Hz or 230V/50Hz)

5. ENVIRONMENT

5.1 Operation

Temperature	0 to 50°C
Relative Humidity	10 to 90%, non-condensing

5.2 Shipping and Storage

Temperature	-20 to 60°C
Relative Humidity	5 to 95%, non-condensing

5.3 Altitude

Operating	2000m
Storage	3000m

6. SAFETY

6.1 Underwriters Laboratory (UL) recognition.

The power supply designed to meet UL 60950.

7. ELECTROMAGNETIC COMPATIBILITY (EMC)

7.1 ELECTROSTATIC DISCHARGE (ESD) – IEC 61000-4-2(EN 61000-4-2).

AUDIT: _____ CHECK: _____ DESIGN: _____

7.2 RADIATED SUSCEPTIBILITY – IEC 61000-4-3(EN 61000-4-3).

7.3 ELECTRICAL FAST TRANSIENT / BURST (EFT/B) – IEC 61000-4 -4(EN 61000-4-4).

7.4 SURGE – IEC 61000-4-5(EN 61000-4-5).

7.5 CONDUCTED SUSCEPTIBILITY – IEC 61000-4-6(EN 61000-4-6).

7.6 POWER FREQUENCY MAGNETIC FIELD – IEC 61000-4-8(EN 61000-4-8).

7.7 VOLTAGE DIPS – IEC 61000-4-11(EN 61000-4-11).

7.8 VOLTAGE FLUCTUATIONS – IEC 61000-3-3 (EN 61000-3-3).

7.9 HARMONIC CURRENT EMISSION – IEC61000-3-2(EN 61000-3-2).

7.10 EN55032:Class B Radio interference (CISPR 22).

7.11 ANSI C63.4-2009 / FCC Part 15 Subpart B / ICES-003 Issue 5 Class B 115VAC operation.

8. MTBF

8.1 MTBF (mean time between failures) calculation

The demonstrated MTBF shall be 100,000 hours of continuous operation at 25°C,at 80% load, and nominal line. The MTBF of the power supply be calculated in accordance with MIL-HDBK-217F. The DC FAN is not included.

9. MECHANICAL REQUIREMENTS

9.1 Physical dimension (L180mm*W150mm*H86mm)

(線材組合 & 外露長度僅供參考，可根據客戶要求更改或新增。)

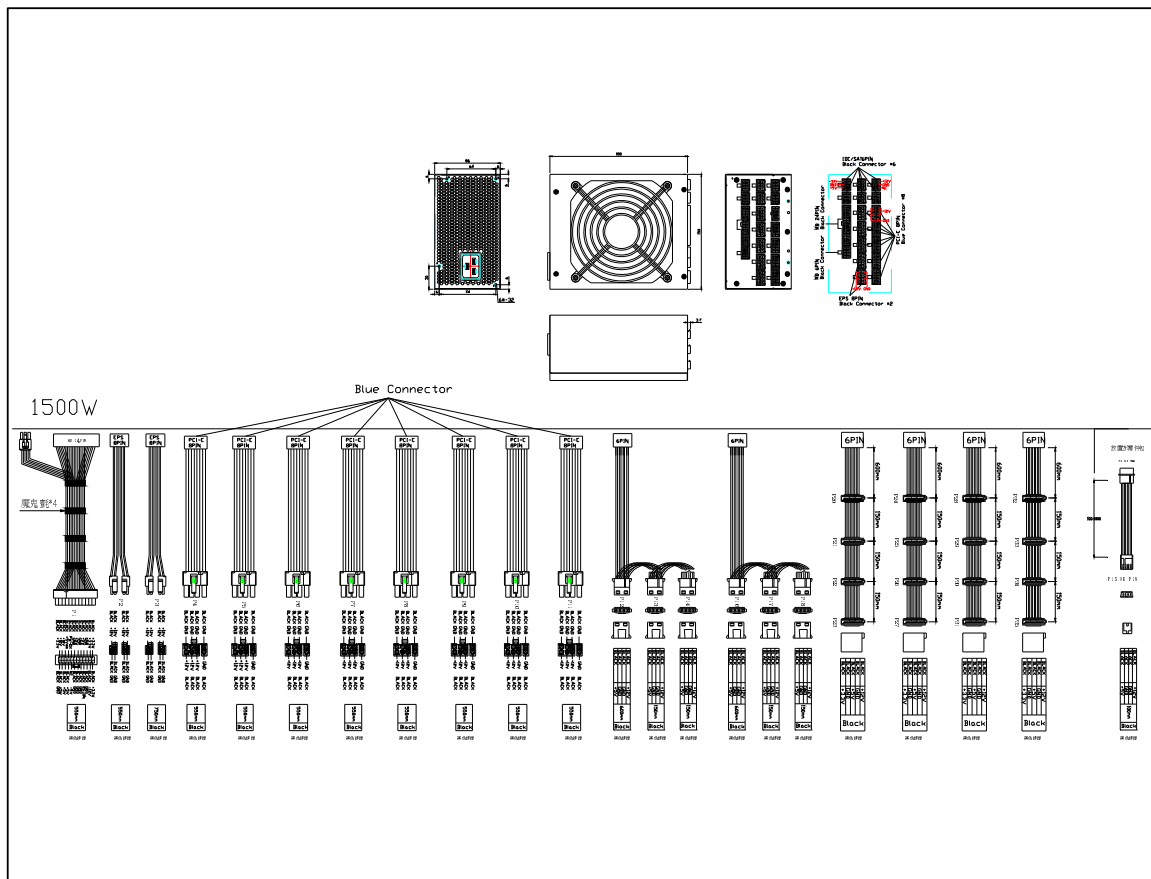

9.2 Connectors (INTEL approved or equivalent)

P1 Connector (24PIN:Molex 44476-1111 or equivalent)

16AWG wire	Signal	Pin	Pin	Signal	16AWG wire
------------	--------	-----	-----	--------	------------

AUDIT: _____ CHECK: _____ DESIGN: _____

Black	+3.3V	11	1	+3.3V	Black
Black(22AWG)	+3.3Vsense				Black
Black(20WAG)	-12V	12	2	+3.3V	Black
Black	GND	13	3	GND	Black
Black(20WAG)	PS-ON	14	4	+5VDC	Black
				+5Vsense	Black(22WAG)
Black	GND	15	5	GND	Black
Black	GND	16	6	+5VDC	Black
Black	GND	17	7	GND	Black
White	NC	18	8	PW-OK	Black(20WAG)
Black	+5V	19	9	+5Vsb	Black(18WAG)
Black	+5V	20	10	+12V	Black
Black	+5V	T3	T1	+12V	Black
Black	GND	T4	T2	+3.3V	Black

P2,P3 Connector ((4+4)PIN:Molex 44476-1111 or equivalent)

16AWG wire	Signal	Pin	Pin	Signal	16AWG wire
Black	+12V	3	1	GND	Black
Black	+12V	4	2	GND	Black

P4,P5,P6 ,P7 PCI (6+2)PIN ((6+2)PIN:Molex AP102XN8T1-204X-RS1 or equivalent)

P8,P9,P10,P11 PCI (6+2)PIN ((6+2)PIN:Molex AP102XN8T1-204X-RS1 or equivalent)

16AWG wire	Signal	Pin	Pin	Signal	16AWG wire
Black	+12V	1	4	GND	Black
Black	+12V	2	5	GND	Black
Black	+12V	3	6	GND	Black
Black	GND	1	2	GND	Black

P15,P19 litter 4Pin

P12,P13,P14,P16,P17,P18 large 4PIN(AMP 1-480424-0 orMolex 8981-04P or equivalent)

18 AWG wire	Signal	Pin
Black	+12V	1
Black	GND	2
Black	GND	3
Black	+5V	4

P20-23,P24-27,P28-31,P32-35 SATA Power Connector (Molex* 88751 or equivalent)(optional)

18AWG wire	Signal	Pin
Black	+3.3V	5
Black	GND	4
Black	+5V	3
Black	GND	2
Black	+12V	1

10.Fan Speed Control

Fan voltage varies with the ambient temperature