

## MODEL NO. ENP7170&7175&7180(ACTIVE PFC)

This specification describes the requirements of **700W,750W,800Watts** with full range voltage, switching power supply with a Micro-ATX(SFX 1.1) form-factor and SFX 12V,'+5V standby voltage, remote on/off .

### 1.0 AC INPUT

#### 1.1 AC input requirements

The input voltage, current, and frequency requirements for continuous operation are stated below.

Parameter	Min	Nom	Max	Unit
Vin	90	<b>100 --- 240</b>	264	VACrms
Vin Frequency	47	<b>60 --- 50</b>	63	Hz
Iin(700W,750W)		<b>10 --- 5</b>		Arms
Iin(800W)		<b>12 --- 6</b>		Arms

Power factor correction (PF)>0.90 at full load.

#### 1.2 Inrush current regulation

The power supply must meet inrush requirements for any rated AC voltage, during turn on at any phase of AC voltage, during a single cycle AC dropout condition, during repetitive ON/OFF cycling of AC, and over the specified temperature range (Top). The peak inrush current shall be less than the ratings of its critical components (including input fuse, bulk rectifiers, and surge limiting device).

### 2.0 DC OUTPUT

#### 2.1 DC voltage regulation

Parameter	Range	Min	Nom.	Max	Unit
+3.3V	±3%	+3.2	+3.3	+3.4	Volts
+5V	±3%	+4.85	+5.0	+5.15	Volts
+12V	±3%	+11.64	+12.0	+12.36	Volts
-12V	±10%	-10.8	-12.0	-13.2	Volts
+5VSb	±5%	+4.75	+5.0	+5.25	Volts

( 1 )At no load,3.3V output +/-5% regulation limits do not apply.

#### 2.2 Load range (700W)

Parameter	Min	Nom.	Max	Peak	Unit
+3.3V	0.1	-	<b>16</b>		Amps
+5V	0.2	-	<b>15</b>		Amps
+12V	0.15	-	<b>58</b>		Amps
-12V	0	-	<b>0.3</b>		Amps
+5VSb	0	-	<b>2.5</b>		Amps

( 1 ) The maximum combined load on +5V and +3.3V outputs shall not exceed **80W**.

( 2 ) The maximum combined load on +12V outputs shall not exceed **696W(58A)**.

( 3 ) The maximum continuous average DC outputs power shall not exceed **700W**.

( 4 ) The peak **750W** DC outputs power shall last no more than **12s**.

**2.3 Load range (750W)**

Parameter	Min	Nom.	Max	Peak	Unit
+3.3V	0.1	-	<b>16</b>		Amps
+5V	0.2	-	<b>15</b>		Amps
+12V	0.15	-	<b>62</b>		Amps
-12V	0	-	<b>0.3</b>		Amps
+5VSb	0	-	<b>2.5</b>		Amps

- ( 1 ) The maximum combined load on +5V and +3.3V outputs shall not exceed **80W**.  
 ( 2 ) The maximum combined load on +12V outputs shall not exceed **744W(62A)**.  
 ( 3 ) The maximum continuous average DC outputs power shall not exceed **750W**.  
 ( 4 ) The peak **800W** DC outputs power shall last no more than **12s**.

**2.4 Load range (800W)**

Parameter	Min	Nom.	Max	Peak	Unit
+3.3V	0.1	-	<b>16</b>		Amps
+5V	0.2	-	<b>15</b>		Amps
+12V	0.15	-	<b>66</b>		Amps
-12V	0	-	<b>0.3</b>		Amps
+5VSb	0	-	<b>2.5</b>		Amps

- ( 1 ) The maximum combined load on +5V and +3.3V outputs shall not exceed **80W**.  
 ( 2 ) The maximum combined load on +12V outputs shall not exceed **792W(66A)**.  
 ( 3 ) The maximum continuous average DC outputs power shall not exceed **800W**.  
 ( 4 ) The peak **850W** DC outputs power shall last no more than **12s**.

**2.5 Output Ripple****2.5.1 Ripple regulation**

Parameter	Ripple&Noise	Unit
+3.3V	<b>50</b>	mVp-p
+5V	<b>50</b>	mVp-p
+12V	<b>120</b>	mVp-p
-12V	<b>120</b>	mVp-p
+5VSb	<b>50</b>	mVp-p

**2.5.2 Definition**

The ripple voltage of the outputs shall be measured at the pins of the output connector when terminated in the load impedance specified in figure1. Ripple and noise are measured at the connectors with a 0.1uF ceramic capacitor and a 10uF electrolytic capacitor to simulate system loading. Ripple shall be measured under any condition of line voltage, output load, line frequency, operation temperature.

**2.5.3 Ripple voltage test circuit**

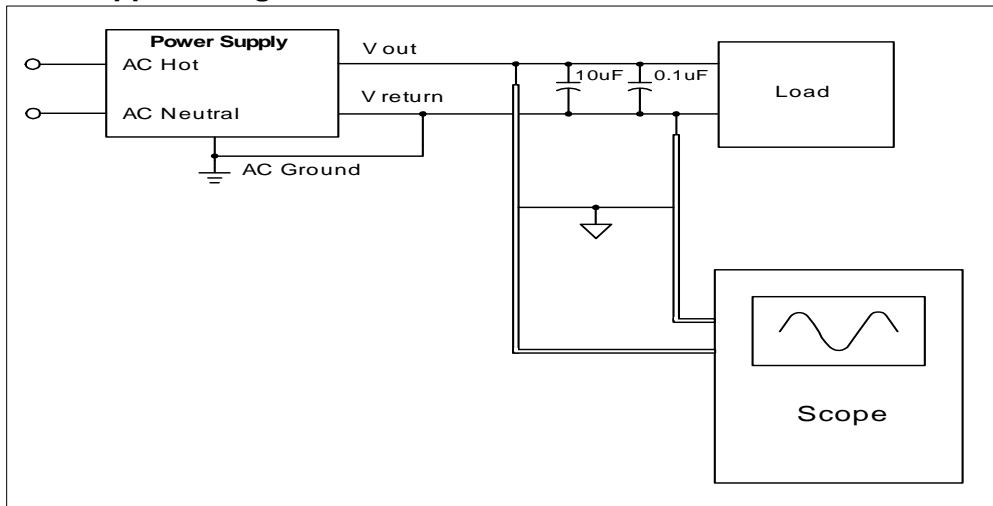

**Figure 1. Ripple voltage test circuit**

**2.6 Overshoot**

Any overshoot at turn on or turn off shall be less 10% of the nominal voltage value, all outputs shall be within the regulation limit of section 2.0 before issuing the power good signal of section 5.0.

**2.7 Efficiency**

Power supply efficiency typical **90%** for at normal voltage at full load on all outputs.

**2.8 Remote on/off control**

When the logic level "PS-ON" is low, the DC outputs are to be enabled.

When the logic level is high or open collector, the DC outputs are to be disabled.

**3.0 PROTECTION**

**3.1 Over-power protection**

The power supply will be shutdown and latch off when output power over 110% ~ 160% of rated DC output.

**3.2 Over current protection**

The power supply shall have current limit to prevent the +3.3V,+5V,and +12V outputs from exceeding the values shown in the following Table. If the current limits are exceeded the power supply shall shutdown and latch off.

Voltage	Over Current Limit (Iout limit)
+12V(700W)	60A minimum; 80A maximum
+12V(750W)	65A minimum; 85A maximum
+12V(800W)	70A minimum; 90A maximum
+5V	20A minimum; 45A maximum
+3.3V	20A minimum; 45A maximum

### 3.3 Over voltage protection

The over voltage sense circuitry and reference shall reside in packages that are separate and distinct from the regulator control circuitry and reference. No single point fault shall be able to cause a sustained over voltage condition on any or all outputs. The supply shall provide latch-mode over voltage protection as defined in Table.

Output	Minimum	Nominal	Maximum	Unit
+12 VDC	13.4	15.0	16.5	Volts
+5 VDC	5.74	6.3	7.0	Volts
+3.3 VDC	3.76	4.2	5.1	Volts

### 3.4 Short circuit

An output short circuit is defined as any output impedance of less than 0.1 ohms. The power supply shall shut down and latch off for shorting the +3.3 VDC,+5 VDC,or+12 VDC rails to return or any other rail. Shorts between main output rails and +5VSB shall not cause any damage to the power supply. The power supply shall either shut down and latch off or fold back for shorting the negative rails.+5VSB must be capable of being shorted indefinitely, but when the short is removed,the power supply shall recover automatically or by cycling PS\_ON#. The power supply shall be capable of withstanding a continuous short-circuit to the output without damage or overstress to the unit

### 3.5 No load operation

No damage or hazardous condition should occur with all the DC output connectors disconnected from the load. The power supply may latch into the shutdown state.

## 4.0 TIMING

### 4.1 Signal timing drawing

Figure 2 is a reference for signal timing for main power connector signals and rails.

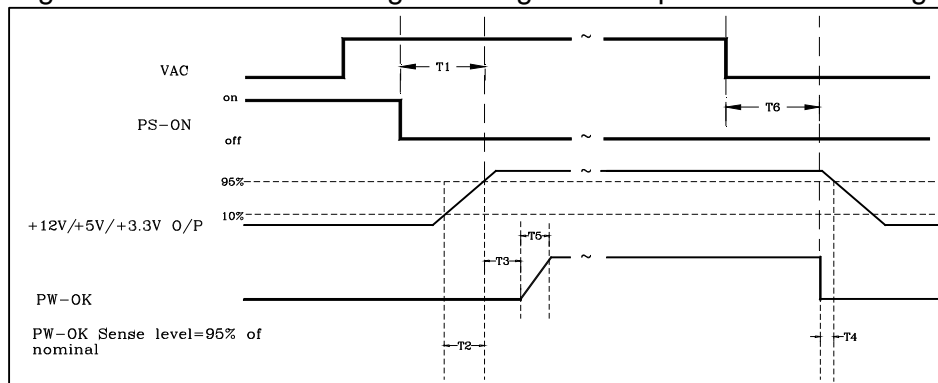

**Figure 2. PS-OK Timing Sequence**

- (1)T2: Rise time (0.2ms~20ms)
- (2)T3: Power good signal turn on delay time (100ms~500ms)
- (3)T4: Power good signal turn off delay time (1ms min)
- (4)T5: Rise time (10ms max)

**4.2 Output Transient Response**

Table 13. summarizes the expected output transient step sizes for each output. The transient load slew rate is =1.0A/us.

**Table 13. DC Output Transient Step Sizes**

Output	Max.step size (% of rated output amps per Sec 3.2.3) <sup>(1)</sup>	Max.step size (amps)
+12 VDC	40%	
+5 VDC	30%	
+3.3 VDC	30%	
-12 VDC		0.1A
+5 VSB		0.5A

<sup>(1)</sup> For example, for a rated +5 VDC output of 18A,the transient step would be 30% x 18A=5.4A  
Output voltages should remain within the regulation limits of Section 2.1, and the power supply should be stable when subjected to load transients per Table 13. from any steady state load, including any or all of the following conditions:

- \*Simultaneous load steps on the +12 VDC,+5 VDC,and +3.3 VDC outputs  
(all steps occurring in the same direction)
- \*Load-changing repetition rate of 50 Hz to 10 kHz
- \*AC input range per Section 1.0

**4.3 Hold up time**

When the power loss its input power, it shall maintain **13ms at 75% load** in regulation limit at nominal input voltage. (AC:115V/60Hz or 230V/50Hz)

**5.0 ENVIRONMENT**

**5.1 Operation**

Temperature	0°C to 40°C
Relative Humidity	20% to 85%,on-condensing

**5.2 Shipping and Storage**

Temperature	-20 to 90°C
Relative Humidity	10% to 95%,non-condensing

**5.3 Altitude**

Operating	2000m
Storage	3000m

**6.0 SAFETY**

**6.1 Underwriters Laboratory (UL) recognition.**

The power supply designed to meet UL 60950

☛ 7.0 ELECTROMAGNETIC COMPATIBILITY (EMC)

- 7.1 ELECTROSTATIC DISCHARGE (ESD) – IEC 61000-4-2(EN 61000-4-2).
- 7.2 RADIATED SUSCEPTIBILITY – IEC 61000-4-3(EN 61000-4-3).
- 7.3 ELECTRICAL FAST TRANSIENT / BURST ( EFT/B) – IEC 61000-4 -4(EN 61000-4-4).
- 7.4 SURGE – IEC 61000-4-5(EN 61000-4-5).
- 7.5 CONDUCTED SUSCEPTIBILITY – IEC 61000-4-6(EN 61000-4-6).
- 7.6 POWER FREQUENCY MAGNETIC FIELD – IEC 61000-4-8(EN 61000-4-8).
- 7.7 VOLTAGE DIPS – IEC 61000-4-11(EN 61000-4-11).
- 7.8 VOLTAGE FLUCTUATIONS – IEC 61000-3-3 (EN 61000-3-3).
- 7.9 HARMONIC CURRENT EMISSION – IEC61000-3-2(EN 61000-3-2).
- 7.10 EN55032:Class B Radio interference (CISPR 22).
- 7.11 ANSI C63.4-2009 / FCC Part 15 Subpart B / ICES-003 Issue 5 Class B 115VAC operation.

☛ 8.0 MTBF

8.1 MTBF (mean time between failures) calculation

The demonstrated MTBF shall be 100,000 hours of continuous operation at 25°C of full load and 120V AC input. The MTBF of the power supply shall be calculated in accordance with MIL-HDBK-217F. The DC FAN is not included.

☛ 9.0 MECHANICAL REQUIREMENTS

9.1 Physical dimension Dim (L125\*W130\*H63.5)

(線材組合&外露長度僅供參考，可根據客戶要求更改或新增。)

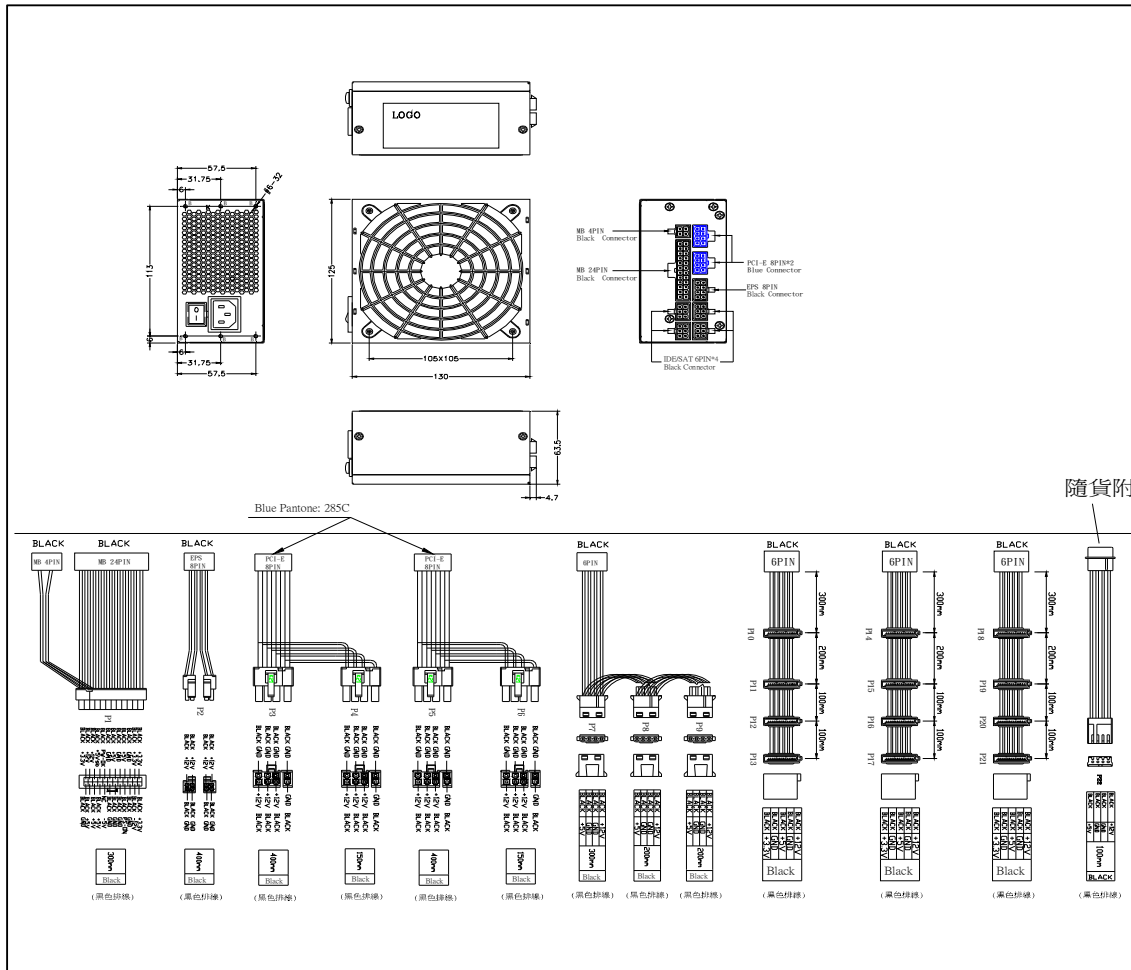

**9.2 Connectors (INTEL approved equivalent)****P1 connector (Molex 39-01-2200 or equivalent)**

18AWG wire	Signal	Pin	Pin	Signal	18AWG wire
Black	+3.3V	11	1	+3.3V	Black
Black(22AWG)	3.3 sense				
Black	-12VDC	12	2	+3.3V	Black
Black	GND	13	3	GND	Black
Black	PS-ON	14	4	+5VDC	Black
				+5V sense	Black (22AWG)
Black	GND	15	5	GND	Black
Black	GND	16	6	+5VDC	Black
Black	GND	17	7	GND	Black
White	NC	18	8	POK	Black
Black	+5VDC	19	9	+5VSB	Black
Black	+5VDC	20	10	+12VDC	Black
Black	+12VDC	M1	M3	+5VDC	Black
Black	+3.3V	M2	M4	GND	Black

**P2 Connector (4+4)PIN:Molex 39-01-2080 or equivalent)**

18 AWG wire	Signal	Pin	Pin	Signal	18AWG wire
Black	GND	1	3	Yellow	Black
Black	GND	2	4	Yellow	Black

**P3,P4 (6+2)PIN (Molex 90331-0010 or equivalent)**

18AWG wire	Signal	Pin	Pin	Signal	18AWG wire
Black	+12VDC	1	4	GND	Black
Black	+12VDC	2	5	GND	Black
Black	+12VDC	3	6	GND	Black
Black	GND	1	2	GND	Black

**P5,P6 HDD(AMP 1-480424-0 or Molex 8981-04P or equivalent)**

18 AWG wire	Signal	Pin	Pin	Signal	22AWG wire
Black	+12VDC	1	1	+12VDC	Black
Black	GND	2	2	GND	Black
Black	GND	3	3	GND	Black
Black	+5VDC	4	4	+5VDC	Black

**P7 FDD(AMP 171822-4 or equivalent)****P8,P9,P10,P11,P12,P13,P14,P15 SATA Power Connector (Molex\* 88751 or equivalent)(optional)**

18AWG wire	Signal	Pin
Black	+12VDC	1
Black	GND	2
Black	+5VDC	3
Black	GND	4
Black	+3.3V	5

**10. FAN SPEED CONTROL**

Fan voltage varies with the ambient temperature and/or output power.