

This specification defines ATX multiple output switching power supply. The parameters of this supply are defined in this specification for Family using. This specification defines max continuous output at **1100W,1300W** with 100 to 240Vac input, and **1500W,1650W** with 115 to 240Vac input . and **2000W** with 200V to 240Vac input power supply with five outputs; +3.3V, +5V, +12V, -12V and +5VSB. The +5V standby voltage, remote on/off control, full range line input capability.An IEC connector is provided on the external face for AC input to the power supply. The power supply contains fans for cooling, while meeting acoustic requirements.

Note:The type of machine is ATX3900 system, the latter two digits represent Watt number, the column ATX3911 (1100W).... ATX3916 (1650W), ATX3920(2000W).

1. AC input characteristics:

1.1 AC input requirements:

The input voltage, current, and frequency requirements for continuous operation are stated show in Table 1.

Table1 A

Parameter	Min	Nom	Max	Unit
Vin	90	100 --- 240	264	VACrms
Vin Frequency	47	60 --- 50	63	Hz
Iin (1100W)	13.5	12.5 --- 6	4.5	A
Iin (1300W)	16	15 --- 7.5	5.5	A

Table1 B

Parameter	Min	Nom	Max	Unit
Vin	103	115 --- 240	264	VACrms
Vin Frequency	47	60 --- 50	63	Hz
Iin (1500W)	16	16 --- 8	6.5	A
Iin (1650W)	16	16 --- 9	7	A

Table1 C

Parameter	Min	Nom	Max	Unit
Vin	180	200 --- 240	264	VACrms
Vin Frequency	47	50	63	Hz
Iin (2000W)	12.5	12	8.5	A

1.2 AC inrush current(cold start):

The power supply must meet inrush requirements for any rated AC voltage, during turn on at any phase. of AC voltage, during a single cycle AC dropout condition, during repetitive ON/OFF cycling of AC, and over the specified temperature range .The peak inrush current shall be less than the ratings of its critical components (including input fuse, bulk rectifiers, and surge limiting device).

Note: Enhance Design Internal Standard: Vac input 115V 50A MAX, Vac input 230V 100A MAX.

Revision: 1.1		Date: 2019/09/26	Page 1 of 12
---------------	---	------------------	--------------

2. DC Output characteristics:

2.1 Output voltage regulation Requirements:

The power supply output voltage must stay within the following voltage limits shown in Table2 when operating at steady state.

Table2

Parameter	Range	Min	Nom.	Max	Unit
+3.3V	±5%	+3.14	+3.30	+3.47	Volts
+5V	±5%	+4.75	+5.0	+5.25	Volts
+12V	±5%	+11.4	+12.0	+12.6	Volts
-12V	±10%	-10.8	-12.0	-13.2	Volts
+5VSB	±5%	+4.75	+5.0	+5.25	Volts

2.2 Output Current Requirements:

The power supply output current following shown in Table3.

Table3

ATX3911(1100W)

Parameter	Min	Max	Peak	Unit
+3.3V	0	25		Amps
+5V	0	22		Amps
+12V	0	92		Amps
-12V	0	0.3		Amps
+5VSB	0	3		Amps

Notes:

- 1.The maximum continuous average DC output power shall not exceed 1100W.
- 2.Maximum continuous combined load on +3.3V and +5V outputs shall not exceed 120W.

ATX3913(1300W)

Parameter	Min	Max	Peak	Unit
+3.3V	0	25		Amps
+5V	0	22		Amps
+12V	0	108		Amps
-12V	0	0.3		Amps
+5VSB	0	3		Amps

Notes:

- 1.The maximum continuous average DC output power shall not exceed 1300W.
- 2.Maximum continuous combined load on +3.3V and +5V outputs shall not exceed 120W.

Revision: 1.1		Date: 2019/09/26	Page 2 of 12
---------------	---	------------------	--------------

ATX3915(1500W)

Parameter	Min	Max	Peak	Unit
+3.3V	0	25		Amps
+5V	0	22		Amps
+12V	0	125		Amps
-12V	0	0.3		Amps
+5VSB	0	3		Amps

Notes:

- 1.The maximum continuous average DC output power shall not exceed 1500W.
- 2.Maximum continuous combined load on +3.3V and +5V outputs shall not exceed 120W.

ATX3916(1650W)

Parameter	Min	Max	Peak	Unit
+3.3V	0	25		Amps
+5V	0	22		Amps
+12V	0	137		Amps
-12V	0	0.3		Amps
+5VSB	0	3		Amps

Notes:

- 1.The maximum continuous average DC output power shall not exceed 1650W.
- 2.Maximum continuous combined load on +3.3V and +5V outputs shall not exceed 120W.

ATX3920 (2000W)

Parameter	Min	Max	Peak	Unit
+3.3V	0	25		Amps
+5V	0	22		Amps
+12V	0	166		Amps
-12V	0	0.3		Amps
+5VSB	0	3		Amps

Notes:

- 1.The maximum continuous average DC output power shall not exceed 2000W.
- 2.Maximum continuous combined load on +3.3V and +5V outputs shall not exceed 120W.

Revision: 1.1		Date: 2019/09/26	Page 3 of 12
---------------	---	------------------	--------------

2.3 Output Transient Response:

Table 4 summarizes the expected output transient step sizes for each output.
The transient load slew rate is = 1.0 A/ μ s.+12V Min load 1A for 0%~85% load.

Table4

Parameter	Maximum Step Size (% of rated output amps)	Maximum Step Size (A)
+3.3V	30% load	
+5V	30% load	
+12V	85% load	1A
-12V		0.1A
+5VSB		0.5A

NOTES:

1. For example, for a rated +5 VDC output of 14A, the transient step would be 30% x 14 A = 4.2 A.
2. Output voltages should remain within the regulation limits of Section 2.1, and the power supply should stable when subjected to load transients per Table 3. from any steady state load, including any or all of the following conditions:
3. Simultaneous load steps on the +12 VDC, +5 VDC, and +3.3 VDC outputs (all steps occurring in the same direction)
4. Load-changing repetition rate of 50 Hz to 10 kHz
5. AC input range per Section 1.1 and Capacitive loading per Table 8.

2.4 Output Ripple and Noise:

Table5

Output	Ripple and Noise	Unit
+3.3V	30	mVp-p
+5V	30	mVp-p
+12V	60	mVp-p
-12V	60	mVp-p
+5VSB	30	mVp-p

Note:

This is measured over a bandwidth of 10Hz to 20MHz at the power supply output connector. A 10 μ F electrolytic capacitor in a parallel with a 0.1 μ F ceramic capacitor is placed at the point of measurement.
Differential noise test setup

Revision: 1.1		Date: 2019/09/26	Page 4 of 12
---------------	---	------------------	--------------

AUDIT: _____ CHECK: _____ DESIGN: 廖小軍

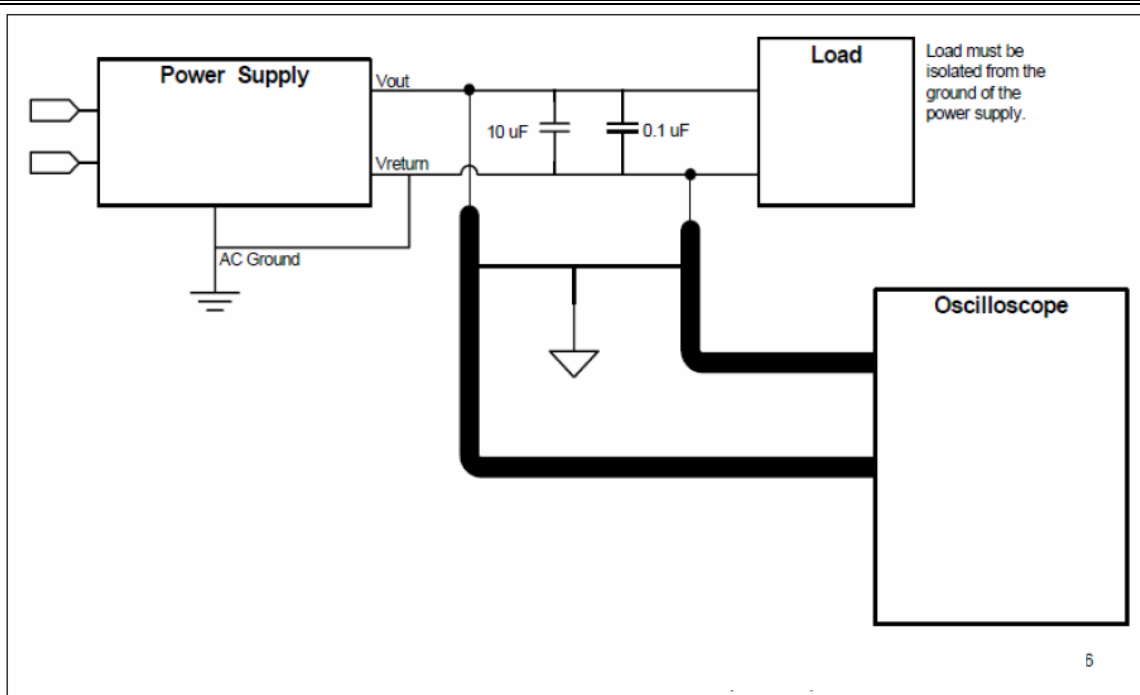

Figure 1

2.5 Efficiency:

2.5.1 In the 115Vac/60Hz input voltage the power supply efficiency is more than 94%.

Table 6 A

1100W,1300W,1500W,1650W:

Load	Efficiency(%)	Power Factor
10%	--	--
20%	90	>0.95
50%	92	>0.95
100%	89	>0.95

Note: There is a 0.5% tolerance in mass production

2.5.2 In the 230Vac/60Hz input voltage the power supply efficiency is more than 94%.

2000W:

Table 6 B

Load	Efficiency(%)	Power Factor
10%	--	--
20%	92	--
50%	94	>0.95
100%	90	>0.95

Note: There is a 0.5% tolerance in mass production

2.5.3 ERP 5VSB Efficiency

Table7

+5VSB LOAD	Efficiency target (both 110V and 230V input)
3A	75%
1.5A	75%
1A	75%
0.55A	75%
45mA	50%

2.6 Remote on/off control

When the logic level "PS-ON" is low, the DC outputs are to be enabled.

When the logic level is high or open collector, the DC outputs are to be disabled.

2.7 Overshoot:

The overshoot of the DC output voltage caused by switching AC power or switch PS-ON# should be less than 10% of the normal output, and no reverse polarity voltage should be produced.

2.8 Capacitance Loading

The power supply shall be stable and meet all requirements with the following capacitive loading ranges.

Table8

Capacitive Loading Conditions	
Output	Capacitive Load (μF)
+3.3V	3,300
+5V	3,300
+12V	3,300
-12V	3,30
+5VSB	3,300

3.Environment:

3.1 Operation temperature:

Table9

Temperature	0 to 50°C
Relative Humidity	5% to 85%,on-condensing

3.2 Shipping and Storage:

Table10

Temperature	-40°C ~ 70°C
Relative Humidity	5% to 95%,non-condensing

3.3 Altitude:

Table11

Operating	≤2000m
Storage	≤3000m

3.4 Cooling mode:

Forced air cooling.

3.5 Random Vibration:

Non-operating 0.01 g²/Hz at 5 Hz, sloping to 0.02 g²/Hz at 20 Hz, and maintaining 0.02 g²/Hz from 20 Hz to 500 Hz. The area under the PSD curve is 3.13 grams.

The duration shall be 10 minutes per axis for all three axes on all samples.

4. Protection:

Due to overvoltage, over power and short circuit, the protection function of the power supply circuit is self operated, and the power is self locked. There is no output at that time. When these reasons are removed, the power is restored to the normal output state when the power is restarted. (PSON# at least 1 second; AC shutdown at least 4 seconds).

4.1 Over-power protection

The power supply will be shutdown and latch off when output power within 110~150% of rated DC output.

Note: Assurance machine can work at low voltage,full load won't damage machine.

4.2 Over voltage protection:

Table12

Output	Output voltage protection point			Unit
	Min	Nom	Max	
+3.3V	3.76	4.2	4.3	V
+5V	5.74	6.3	7.0	V
+12V	13.4	15.0	15.6	V
+5vsb	5.74	6.3	7.0	V

4.3 Short circuit protection:

An output short circuit is defined as any output impedance of less than 0.1 ohms.The power supply shall shut down and latch off for shorting the +3.3 VDC,+5 VDC,or+12VDC rails to return or any other rail. Shorts between main output rails and +5VSB shall not cause any damage to the power supply. The power supply shall either shut down and latch off or fold back for shorting the negative rails.+5VSB must be capable of being shorted indefinitely,but when the short is removed,the power supply shall recover automatically or by cycling PS_ON#.The power supply shall be capable of withstanding a continuous short-circuit to the output without damage or overstress to the unit

Revision: 1.1		Date: 2019/09/26	Page 7 of 12
---------------	---	------------------	--------------

4.4 Over Temperature Protection:

The power supply will be protected against over temperature conditions caused by loss of fan cooling or excessive ambient temperature. In an OTP condition the PSU will shutdown. When the power supply temperature drops to within specific limits, the power supply shall latch mode.

4.5 Over current protection

The power supply shall have current limit to prevent the +3.3 V, +5 V, and +12V outputs from exceeding the values shown in Table . If the current limits are exceeded the power supply shall shutdown and latch off. The damaged from repeated power cycling in this condition. -12V and 5VSB shall be protected under over current or shorted conditions so that no damage can occur to the power supply. All outputs shall be protected so that no damage occurs to the power supply under a shorted output condition.

Table13

Voltage	Over Current Limit (I _{out} limit)
+3.3V	25A minimum; 50A maximum
+5V	25A minimum; 50A maximum
+12V(1100W)	101A minimum; 138A maximum
+12V(1300W)	120A minimum; 163A maximum
+12V(1500W)	130A minimum; 188A maximum
+12V(1650W)	151A minimum; 206A maximum
+12V(2000W)	183A minimum; 250A maximum

5. Power Supply Timing

5.1 Signal timing drawing

Figure 2 is a reference for signal timing for main power connector signals and rails.

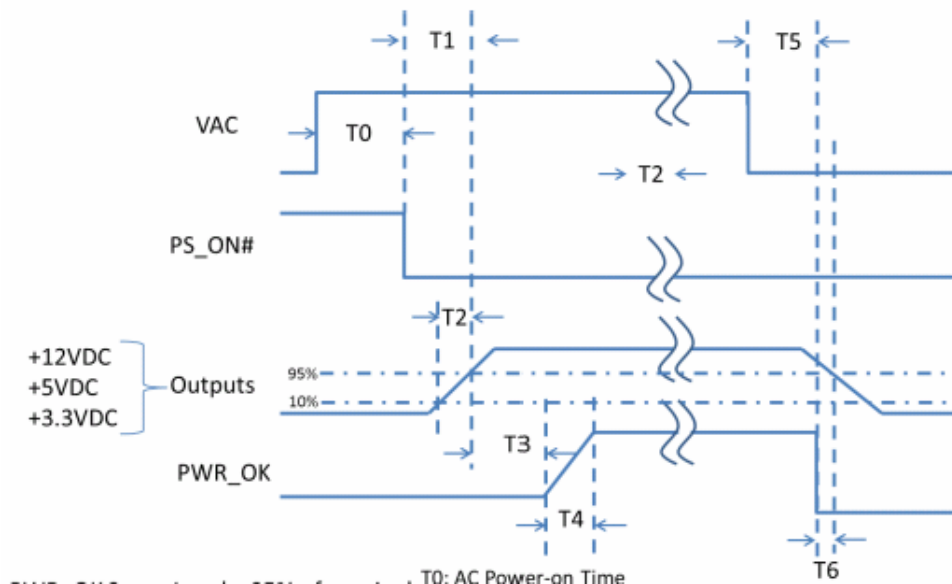

Figure 2

Table14

Parameter	Description	Required
T0	AC power on time	<2s
T1	Power-on time	< 500ms
T2	Rise time	0.2 – 20 ms
T3	PWR_OK delay	100 – 150ms
T4	PWR_OK rise time	< 10 ms
T5	AC loss to PWR_OK hold-up time(1100W,1300W,1500W,1650 at 100 % load)	> 16 ms
	AC loss to PWR_OK hold-up time(2000w at 80% load)	> 16 ms
T6	PWR_OK inactive to DC loss delay	> 1 ms

The power supply should maintain output regulations per Table 5 despite a loss of input power at the low-end nominal range-115 VAC / 47 Hz or 230 VAC / 47 Hz – at maximum continuous output load as applicable for a minimum of 17ms (T5+T6)

6. SAFETY:

The power supply designed to meet IEC 62368-1.

6.1 Electrical strength:

Gradually increased from 0V to 1500V is applied in the AC line and the casing, and then keep for 1 minutes, the insulation should not breakdown; if the current increases rapidly due to the test voltage and gets out of the way, that is to limit the current insulation, insulation breakdown that has occurred; corona discharge or flashover is not a single moment that is the breakdown of insulation.

6.2 Ground Resistance:

Ground resistance value less than < 0.1 ohm(40A)

6.3 Touch current:

When the input 250Vac, contact current less than 3.5mA at 25°C.

6.4 EMC

6.4.1 ELECTROSTATIC DISCHARGE (ESD) – IEC 61000-4-2(EN 61000-4-2).

6.4.2 RADIATED SUSCEPTIBILITY – IEC 61000-4-3(EN 61000-4-3).

6.4.3 ELECTRICAL FAST TRANSIENT / BURST (EFT/B) – IEC 61000-4 -4(EN 61000-4-4).

6.4.4 SURGE – IEC 61000-4-5(EN 61000-4-5).

6.4.5 CONDUCTED SUSCEPTIBILITY – IEC 61000-4-6(EN 61000-4-6).

6.4.6 POWER FREQUENCY MAGNETIC FIELD – IEC 61000-4-8(EN 61000-4-8).

6.4.7 VOLTAGE DIPS – IEC 61000-4-11(EN 61000-4-11).

Revision: 1.1		Date: 2019/09/26	Page 9 of 12
---------------	---	------------------	--------------

8.2 Connectors (INTEL approved equivalent):

P1 Connector (24PIN:Molex 44476-1111 or equivalent)

16AWG wire	Signal	Pin	Pin	Signal	16AWG wire
Black	+3.3V	11	1	+3.3V	Black
Black(22AWG)	+3.3Vsense				Black
Black(20WAG)	-12V	12	2	+3.3V	Black
Black	GND	13	3	GND	Black
Black(20WAG)	PS-ON	14	4	+5VDC	Black
				+5Vsense	Black(22WAG)
Black	GND	15	5	GND	Black
Black	GND	16	6	+5VDC	Black
Black	GND	17	7	GND	Black
White	NC	18	8	PW-OK	Black(20WAG)
Black	+5V	19	9	+5Vsb	Black(18WAG)
Black	+5V	20	10	+12V	Black
Black	+5V	T3	T1	+12V	Black
Black	GND	T4	T2	+3.3V	Black

P2,P3 Connector ((4+4)PIN:Molex 44476-1111 or equivalent)

16AWG wire	Signal	Pin	Pin	Signal	16AWG wire
Black	+12V	3	1	GND	Black
Black	+12V	4	2	GND	Black

P4,P5,P6 ,P7 PCI (6+2)PIN ((6+2)PIN:Molex AP102XN8T1-204X-RS1 or equivalent)

P8,P9,P10,P11 PCI (6+2)PIN ((6+2)PIN:Molex AP102XN8T1-204X-RS1 or equivalent)

16AWG wire	Signal	Pin	Pin	Signal	16AWG wire
Black	+12V	1	4	GND	Black
Black	+12V	2	5	GND	Black
Black	+12V	3	6	GND	Black
Black	GND	1	2	GND	Black

P15,P19 litter 4Pin

P12,P13,P14,P16,P17,P18 large 4PIN(AMP 1-480424-0 orMolex 8981-04P or equivalent)

18 AWG wire	Signal	Pin
Black	+12V	1
Black	GND	2
Black	GND	3
Black	+5V	4

P20-23,P24-27,P28-31,P32-35 SATA Power Connector (Molex* 88751 or equivalent)(optional)

18AWG wire	Signal	Pin
Black	+3.3V	5
Black	GND	4
Black	+5V	3
Black	GND	2
Black	+12V	1

9. FAN SPEED CONTROL

- 1.Fan voltage varies with the ambient temperature or output power.
- 2.Semi-Fanless function @ **10% max load** at 25°C .

Revision: 1.1		Date: 2019/09/26	Page 12 of 12
---------------	---	------------------	---------------

AUDIT: _____ CHECK: _____ DESIGN: 廖小軍